

APPROVAL SHEET

MULTILAYER CERAMIC CAPACITORS

High Q / Low ESR Series (HH)

0402 & 0603 Sizes

NP0 Dielectric

RoHS Compliance

CUSTOMER: _____

APPROVAL NO.: _____

ISSUE DATE: _____

APPROVED BY: Hank Chiang

CUSTOMER APPROVAL:

MULTILAYER CERAMIC CAPACITORS

High Q / Low ESR Series (HH)



1. INTRODUCTION

MLCC consists of a conducting material and electrodes. To manufacture a chip-type SMT and achieve miniaturization, high density and high efficiency, ceramic condensers are used.

WTC HH series MLCC is used at high frequencies generally have a small temperature coefficient of capacitance, typical within the $\pm 30\text{ppm}/^\circ\text{C}$ required for NP0 (COG) classification and have excellent conductivity internal electrode. Thus, WTC HH series MLCC will be with the feature of low ESR and high Q characteristics.

2. FEATURES

- a. High Q and low ESR performance at high frequency.
- b. Quality improvement of telephone calls for low power loss and better performance.

3. APPLICATIONS

- a. Mobile telecommunication: Mobile phone, WLAN.
- b. RF module: Power amplifier, VCO.
- c. Tuners.

4. HOW TO ORDER

<u>HH</u>	<u>15</u>	<u>N</u>	<u>100</u>	<u>G</u>	<u>500</u>	<u>L</u>	<u>I</u>
<u>Series</u>	<u>Size</u>	<u>Dielectric</u>	<u>Capacitance</u>	<u>Tolerance</u>	<u>Rated voltage</u>	<u>Termination</u>	<u>Packaging</u>
HH=High Q/ Low ESR	15=0402 (1005) 18=0603 (1608)	N=NP0 (COG)	Two significant digits followed by no. of zeros. And R is in place of decimal point. eg.: R47=0.47pF 0R5=0.5pF 1R0=1.0pF 100=10x10 ⁰ =10pF	B= $\pm 0.1\text{pF}$ C= $\pm 0.25\text{pF}$ D= $\pm 0.5\text{pF}$ F= $\pm 1\%$ G= $\pm 2\%$ J= $\pm 5\%$	Two significant digits followed by no. of zeros. And R is in place of decimal point. 160=16 VDC 250=25 VDC 500=50 VDC 101=100 VDC	L=Ag/Ni/Sn	T=7" reeled G= 13" reeled

MULTILAYER CERAMIC CAPACITORS

High Q / Low ESR Series (HH)



5. EXTERNAL DIMENSIONS

Size Inch (mm)	L (mm)	W (mm)	T (mm)/Symbol	M _B (mm)	
0402 (1005)	1.00±0.05	0.50±0.05	0.50±0.05	N	0.25 +0.05/-0.10
0603 (1608)	1.60±0.10	0.80±0.10	0.80±0.07	S	0.40±0.15

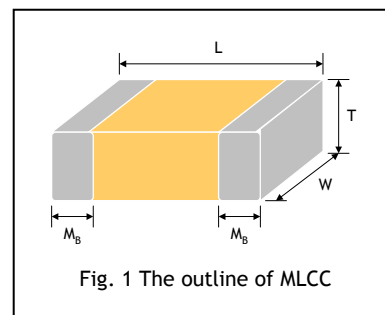

Fig. 1 The outline of MLCC

6. GENERAL ELECTRICAL DATA

Dielectric	NP0
Size	0402, 0603
Capacitance*	0402: 0.5pF to 470pF 0603: 0.5pF to 3300pF
Capacitance tolerance	Cap≤5pF: B (±0.1pF), C (±0.25pF) 5pF<Cap<10pF: C (±0.25pF), D (±0.5pF) Cap≥10pF: F (±1%), G (±2%), J (±5%)
Rated voltage (WVDC)	16V, 25V, 50V, 100V
Q*	Cap<30pF: Q≥400+20C Cap≥30pF: Q≥1000
Insulation resistance at U _r	≥10GΩ
Operating temperature	-55 to +125 °C
Capacitance change	±30ppm
ESR	Cap<2.2pF: ≤1000mΩ@900±100MHz 2.2pF≤Cap≤470pF: ≤500mΩ@900±100MHz Cap>470pF: ≤500mΩ@60±10MHz
Termination	Ni/Sn (lead-free termination)

* Measured at the conditions of 25 °C ambient temperature and 30-70% related humidity.

Apply 1.0±0.2Vrms, 1.0MHz±10% for Cap≤1000pF and 1.0±0.2Vrms, 1.0kHz±10% for Cap>1000pF.

MULTILAYER CERAMIC CAPACITORS

High Q / Low ESR Series (HH)



7. CAPACITANCE RANGE

DIELECTRIC		NPO							
SIZE		0402			0603				
RATED VOLTAGE (VDC)		16	25	50	16	25	50	100	
Capacitance	0.5pF (0R5)		N	N		S	S	S	
	0.6pF (0R6)		N	N		S	S	S	
	0.7pF (0R7)		N	N		S	S	S	
	0.8pF (0R8)		N	N		S	S	S	
	0.9pF (0R9)		N	N		S	S	S	
	1.0pF (1R0)		N	N		S	S	S	
	1.2pF (1R2)			N	N		S	S	S
	1.5pF (1R5)			N	N		S	S	S
	1.8pF (1R8)			N	N		S	S	S
	2.2pF (2R2)			N	N		S	S	S
	2.7pF (2R7)			N	N		S	S	S
	3.3pF (3R3)			N	N		S	S	S
	3.9pF (3R9)			N	N		S	S	S
	4.7pF (4R7)			N	N		S	S	S
	5.6pF (5R6)			N	N		S	S	S
	6.8pF (6R8)			N	N		S	S	S
	8.2pF (8R2)			N	N		S	S	S
	10pF (100)			N	N		S	S	S
	12pF (120)			N	N		S	S	S
	15pF (150)			N	N		S	S	S
	18pF (180)			N	N		S	S	S
	22pF (220)			N	N		S	S	S
	27pF (270)			N	N		S	S	S
	33pF (330)			N	N		S	S	S
	39pF (390)			N	N		S	S	S
	47pF (470)			N	N		S	S	S
	56pF (560)			N	N		S	S	S
	68pF (680)			N	N		S	S	S
	82pF (820)			N	N		S	S	S
	100pF (101)			N	N		S	S	S
	120pF (121)			N	N		S	S	S
	150pF (151)			N	N		S	S	S
	180pF (181)			N	N		S	S	S
220pF (221)			N	N		S	S	S	
270pF (271)	N					S	S	S	
330pF (331)	N					S	S	S	
390pF (391)	N					S	S	S	
470pF (471)	N					S	S	S	
560pF (561)						S	S		
680pF (681)						S	S		
820pF (821)						S	S		
1,000pF (102)						S	S		
1,200pF (122)					S				
1,500pF (152)					S				
1,800pF (182)					S				
2,200pF (222)					S				
2,700pF (272)					S				
3,300pF (332)					S				

1. The letter in cell is expressed the symbol of product thickness.
2. For more information about products with special capacitance or other data, please contact WTC local representative.

MULTILAYER CERAMIC CAPACITORS

High Q / Low ESR Series (HH)



8. PACKAGING DIMENSION AND QUANTITY

Size	Thickness (mm)/Symbol		Paper tape	
			7" reel	13" reel
0402	0.50±0.05	N	10K	20K
0603	0.80±0.07	S	4K	10K

Unit: pieces

9. ELECTRICAL CHARACTERISTICS

Q factor specification vs. Specific frequency

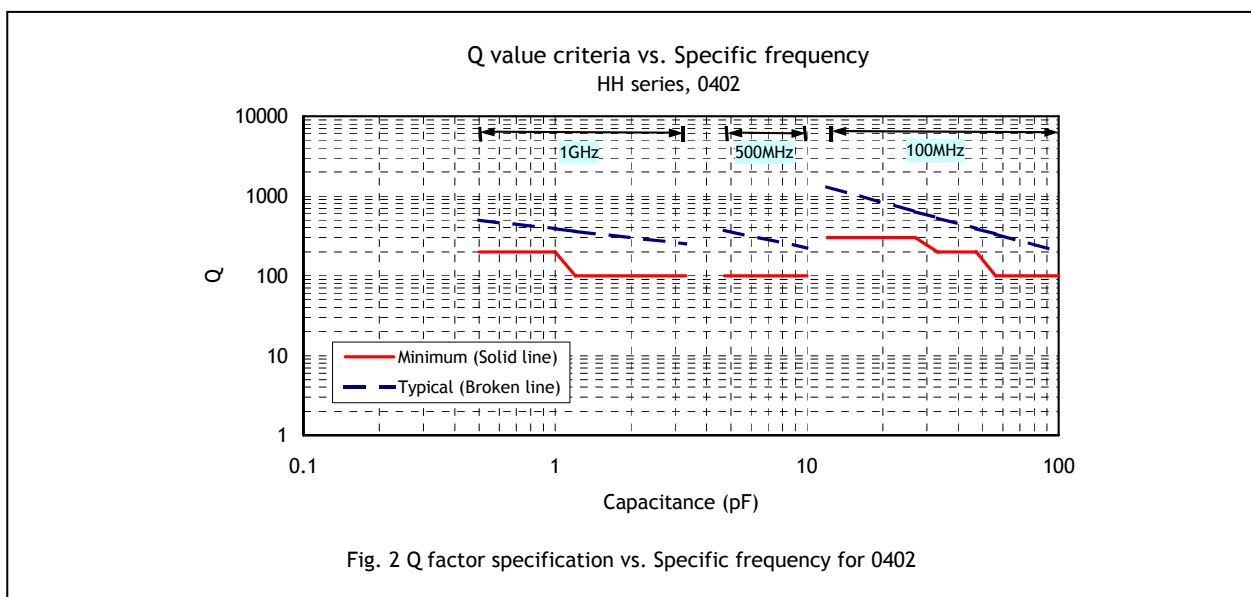

Q factor specification vs. Specific frequency

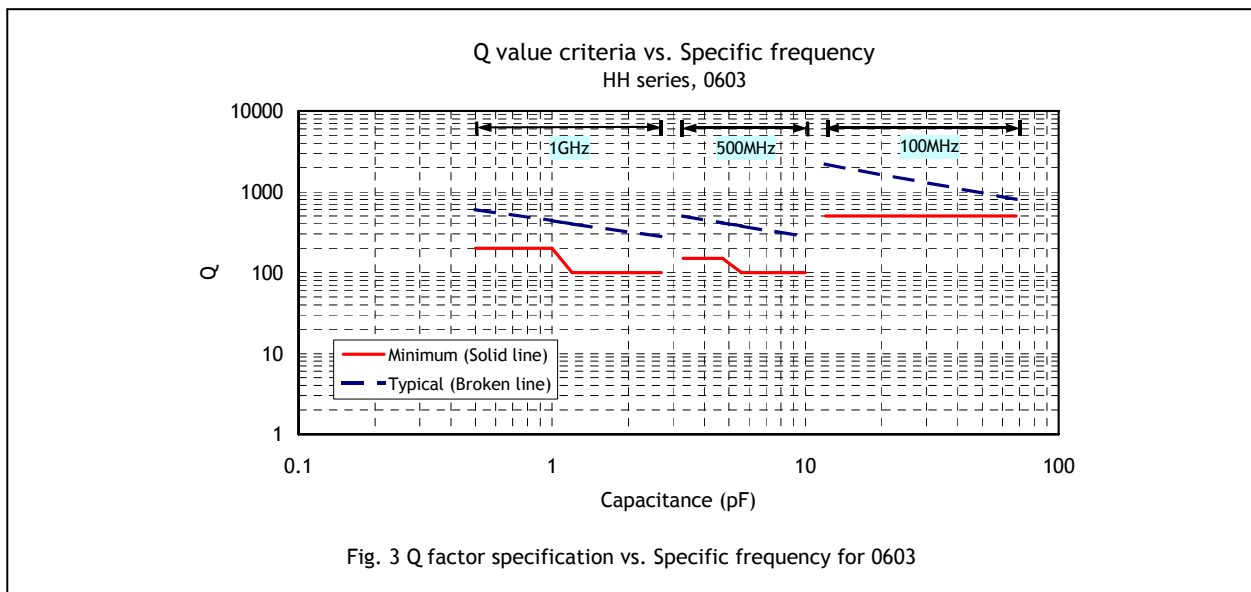

MULTILAYER CERAMIC CAPACITORS

High Q / Low ESR Series (HH)



Typical ESR vs. Frequency

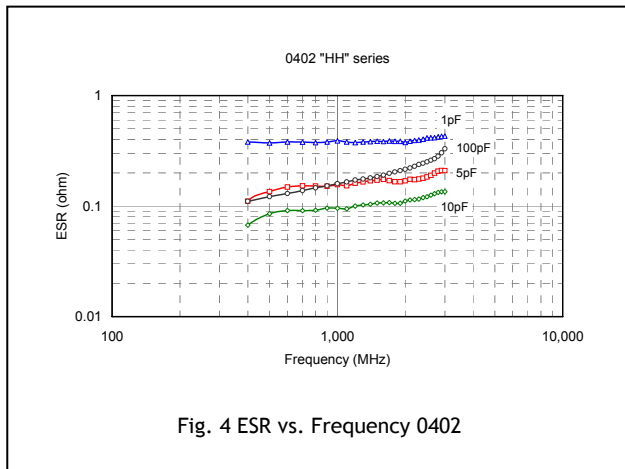

Fig. 4 ESR vs. Frequency 0402

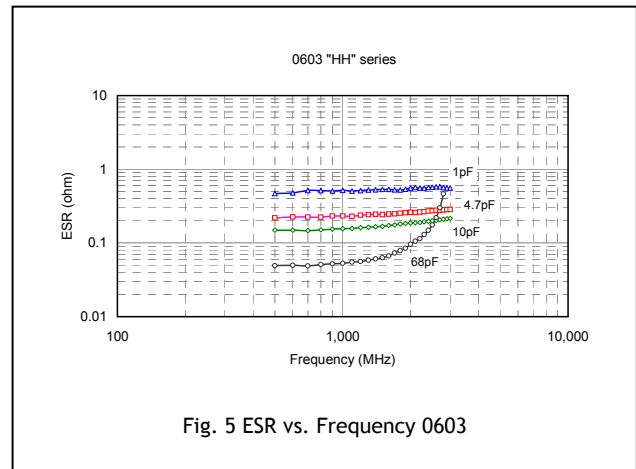

Fig. 5 ESR vs. Frequency 0603

Typical Impedance vs. Frequency

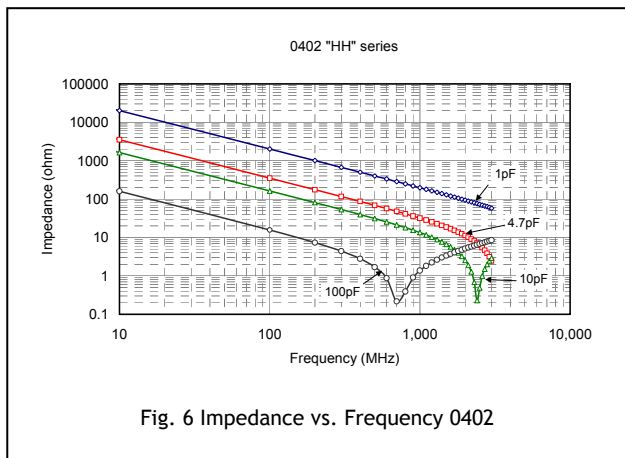

Fig. 6 Impedance vs. Frequency 0402

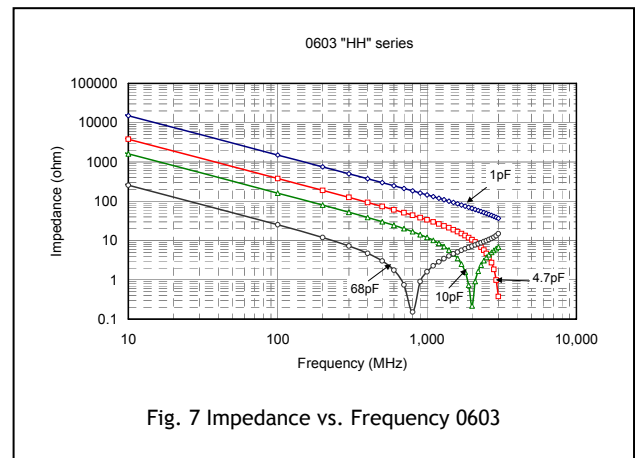

Fig. 7 Impedance vs. Frequency 0603

SRF vs. Capacitance

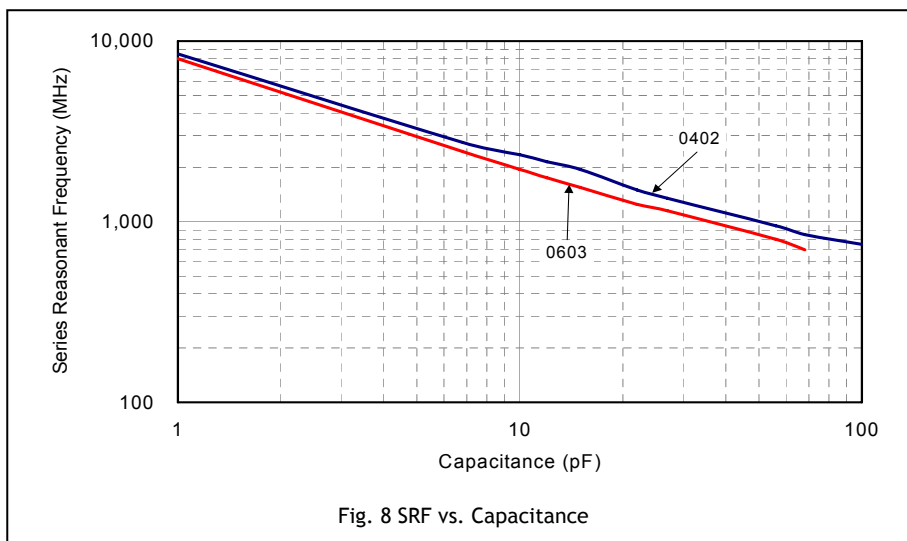

Fig. 8 SRF vs. Capacitance

MULTILAYER CERAMIC CAPACITORS

High Q / Low ESR Series (HH)



10. RELIABILITY TEST CONDITIONS AND REQUIREMENTS

No.	Item	Test Conditions	Requirements															
1.	Visual and Mechanical	---	<ul style="list-style-type: none"> No remarkable defect. Dimensions to conform to individual specification sheet. 															
2.	Capacitance	Cap \leq 1000pF, 1.0 \pm 0.2Vrms, 1MHz \pm 10%	Shall not exceed the limits given in the detailed spec.															
3.	Q/ D.F. (Dissipation Factor)	Cap $>$ 1000pF, 1.0 \pm 0.2Vrms, 1KHz \pm 10% At 25 °C ambient temperature.	NPO: Cap \geq 30pF, Q \geq 1000; Cap $<$ 30pF, Q \geq 400+20C															
4.	Dielectric Strength	<ul style="list-style-type: none"> To apply voltage: 250% of rated voltage. Duration: 1 to 5 sec. Charge and discharge current less than 50mA. 	No evidence of damage or flash over during test.															
5.	Insulation Resistance	To apply rated voltage for max. 120 sec.	\geq 10G Ω															
6.	Temperature Coefficient	<ul style="list-style-type: none"> With no electrical load. Operating temperature: -55-125 °C at 25 °C 	Capacitance change: within \pm 30ppm/°C															
7.	Adhesive Strength of Termination	<ul style="list-style-type: none"> Pressurizing force : 5N (\leq0603) and 10N ($>$0603) Test time: 10\pm1 sec. 	No remarkable damage or removal of the terminations.															
8.	Vibration Resistance	<ul style="list-style-type: none"> Vibration frequency: 10-55 Hz/min. Total amplitude: 1.5mm Test time: 6 hrs. (Two hrs each in three mutually perpendicular directions.) 	<ul style="list-style-type: none"> No remarkable damage. Cap change and Q/D.F.: To meet initial spec. 															
9.	Solderability	<ul style="list-style-type: none"> Solder temperature: 235\pm5 °C Dipping time: 2\pm0.5 sec. 	95% min. coverage of all metalized area.															
10.	Bending Test	<ul style="list-style-type: none"> The middle part of substrate shall be pressurized by means of the pressurizing rod at a rate of about 1 mm per second until the deflection becomes 1 mm and then the pressure shall be maintained for 5\pm1 sec. Measurement to be made after keeping at room temp. for 24\pm2 hrs. 	<ul style="list-style-type: none"> No remarkable damage. Cap change: within \pm5.0% or \pm0.5pF whichever is larger. (This capacitance change means the change of capacitance under specified flexure of substrate from the capacitance measured before the test.) 															
11.	Resistance to Soldering Heat	<ul style="list-style-type: none"> Solder temperature: 270\pm5 °C Dipping time: 10\pm1 sec Preheating: 120 to 150 °C for 1 minute before immerse the capacitor in a eutectic solder. Measurement to be made after keeping at room temp. for 24\pm2 hrs. (Class I) or 48\pm4 hrs. (Class II). 	<ul style="list-style-type: none"> No remarkable damage. Cap change: within \pm2.5% or \pm0.25pF whichever is larger. Q/D.F., I.R. and dielectric strength: To meet initial requirements. 25% max. leaching on each edge. 															
12.	Temperature Cycle	<ul style="list-style-type: none"> Conduct the five cycles according to the temperatures and time. <table border="1"> <thead> <tr> <th>Step</th> <th>Temp. (°C)</th> <th>Time (min.)</th> </tr> </thead> <tbody> <tr> <td>1</td> <td>Min. operating temp. +0/-3</td> <td>30\pm3</td> </tr> <tr> <td>2</td> <td>Room temp.</td> <td>2-3</td> </tr> <tr> <td>3</td> <td>Max. operating temp. +3/-0</td> <td>30\pm3</td> </tr> <tr> <td>4</td> <td>Room temp.</td> <td>2-3</td> </tr> </tbody> </table> <ul style="list-style-type: none"> Measurement to be made after keeping at room temp. for 24\pm2 hrs. 	Step	Temp. (°C)	Time (min.)	1	Min. operating temp. +0/-3	30 \pm 3	2	Room temp.	2-3	3	Max. operating temp. +3/-0	30 \pm 3	4	Room temp.	2-3	<ul style="list-style-type: none"> No remarkable damage. Cap change : within \pm2.5% or \pm0.25pF whichever is larger. Q/D.F., I.R. and dielectric strength: To meet initial requirements.
Step	Temp. (°C)	Time (min.)																
1	Min. operating temp. +0/-3	30 \pm 3																
2	Room temp.	2-3																
3	Max. operating temp. +3/-0	30 \pm 3																
4	Room temp.	2-3																

MULTILAYER CERAMIC CAPACITORS

High Q / Low ESR Series (HH)



No.	Item	Test Condition	Requirements
13.	Humidity (Damp Heat) Steady State	<ul style="list-style-type: none"> Test temp.: $40\pm 2^{\circ}\text{C}$ Humidity: 90-95% RH Test time: 500+24/-0hrs. Measurement to be made after keeping at room temp. for 24±2 hrs. 	<ul style="list-style-type: none"> No remarkable damage. Cap change: within $\pm 5.0\%$ or $\pm 0.5\text{pF}$ whichever is larger. Q/D.F. value: NPO: $\text{Cap}\geq 30\text{pF}$, $\text{Q}\geq 350$; $10\text{pF}\leq\text{Cap}<30\text{pF}$, $\text{Q}\geq 275+2.5\text{C}$ $\text{Cap}<10\text{pF}$; $\text{Q}\geq 200+10\text{C}$ I.R.: $\geq 1\text{G}\Omega$.
14.	Humidity (Damp Heat) Load	<ul style="list-style-type: none"> Test temp.: $40\pm 2^{\circ}\text{C}$ Humidity: 90-95%RH Test time: 500+24/-0 hrs. To apply voltage : rated voltage Measurement to be made after keeping at room temp. for 24±2 hrs. 	<ul style="list-style-type: none"> No remarkable damage. Cap change: within $\pm 7.5\%$ or $\pm 0.75\text{pF}$ whichever is larger. Q/D.F. value: NPO: $\text{Cap}\geq 30\text{pF}$, $\text{Q}\geq 200$; $\text{Cap}<30\text{pF}$, $\text{Q}\geq 100+10/3\text{C}$ I.R.: $\geq 500\text{M}\Omega$.
15.	High Temperature Load (Endurance)	<ul style="list-style-type: none"> Test temp.: NPO, X7R: $125\pm 3^{\circ}\text{C}$ To apply voltage: 200% of rated voltage. Test time: 1000+24/-0 hrs. Measurement to be made after keeping at room temp. for 24±2 hrs. 	<ul style="list-style-type: none"> No remarkable damage. Cap change: within $\pm 3.0\%$ or $\pm 0.3\text{pF}$ whichever is larger. Q/D.F. value: NPO: $\text{Cap}\geq 30\text{pF}$, $\text{Q}\geq 350$ $10\text{pF}\leq\text{Cap}<30\text{pF}$, $\text{Q}\geq 275+2.5\text{C}$ $\text{Cap}<10\text{pF}$, $\text{Q}\geq 200+10\text{C}$ I.R.: $\geq 1\text{G}\Omega$.

11. APPENDIXES

■ Tape & reel dimensions

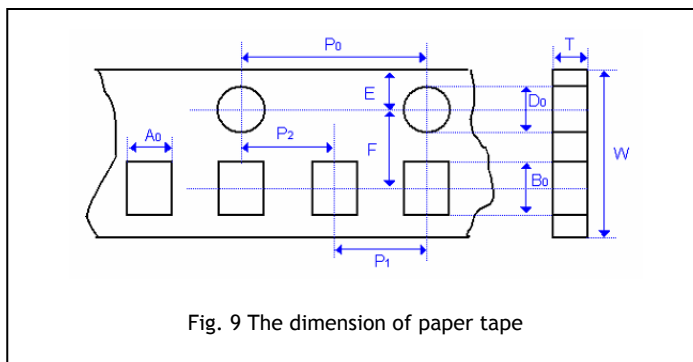

Fig. 9 The dimension of paper tape

Size	0402	0603
Thickness	N	S
A ₀	0.62±0.05	1.02±0.05
B ₀	1.12±0.05	1.82±0.05
T	0.60±0.05	0.95±0.05
K ₀	-	-
W	8.00±0.10	8.00±0.10
P ₀	4.00±0.10	4.00±0.10
10xP ₀	40.0±0.10	40.0±0.10
P ₁	2.00±0.05	4.00±0.10
P ₂	2.00±0.05	2.00±0.05
D ₀	1.55±0.05	1.55±0.05
D ₁	-	-
E	1.75±0.05	1.75±0.05
F	3.50±0.05	3.50±0.05

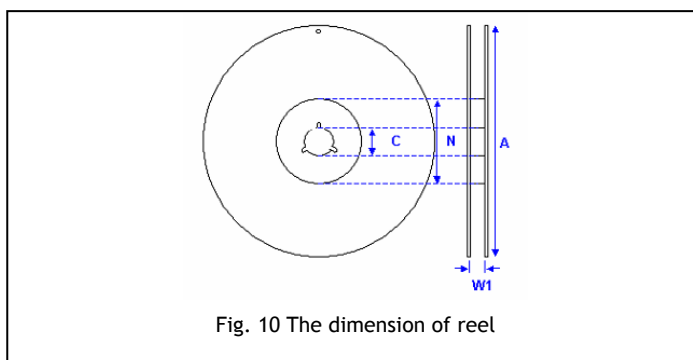

Fig. 10 The dimension of reel

Size	0402, 0603	
Reel size	7"	13"
C	13.0+0.5/-0.2	13.0+0.5/-0.2
W ₁	8.4+1.5/-0	8.4+1.5/-0
A	178.0±1.0	330.0±1.0
N	60.5±1.0	100±1.0

MULTILAYER CERAMIC CAPACITORS

High Q / Low ESR Series (HH)



Description of customer label

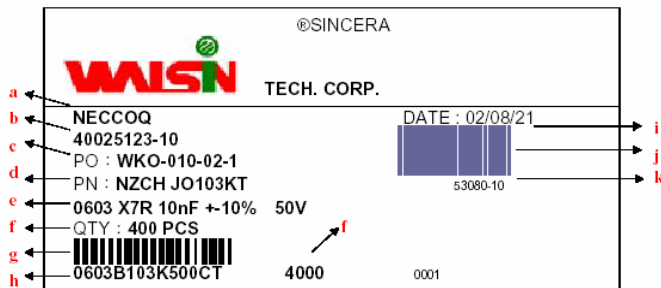

- a. Customer name
- b. WTC order series and item number
- c. Customer P/O
- d. Customer P/N
- e. Description of product
- f. Quantity
- g. Bar code including quantity & WTC P/N or customer
- h. WTC P/N
- i. Shipping date
- j. Order bar code including series and item numbers
- k. Serial number of label

Constructions

No.	Name	NPO	
①	Ceramic material	BaTiO ₃ based	
②	Inner electrode	AgPd alloy	
③	Termination	Inner layer	Ag
④		Middle layer	Ni
⑤		Outer layer	Sn (Matt)

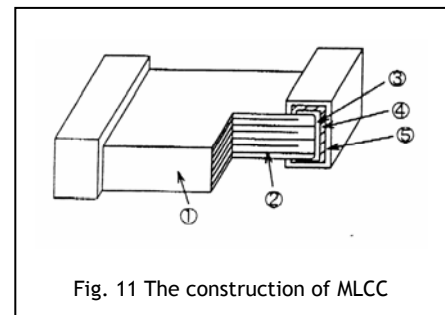

Storage and handling conditions

- (1) To store products at 5 to 40°C ambient temperature and 20 to 70% related humidity conditions.
- (2) The product is recommended to be used within one year after shipment. Check solderability in case of shelf life extension is needed.

Cautions:

- a. Don't store products in a corrosive environment such as sulfide, chloride gas, or acid. It may cause oxidization of electrode, which easily be resulted in poor soldering.
- b. To store products on the shelf and avoid exposure to moisture.
- c. Don't expose products to excessive shock, vibration, direct sunlight and so on.

MULTILAYER CERAMIC CAPACITORS

High Q / Low ESR Series (HH)



Recommended soldering conditions

The lead-free termination MLCCs are not only to be used on SMT against lead-free solder paste, but also suitable against lead-containing solder paste. If the optimized solder joint is requested, increasing soldering time, temperature and concentration of N_2 within oven are recommended.

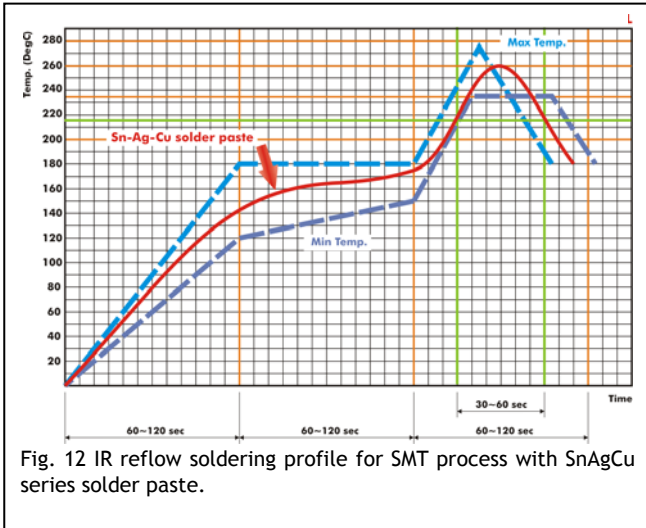

Fig. 12 IR reflow soldering profile for SMT process with SnAgCu series solder paste.

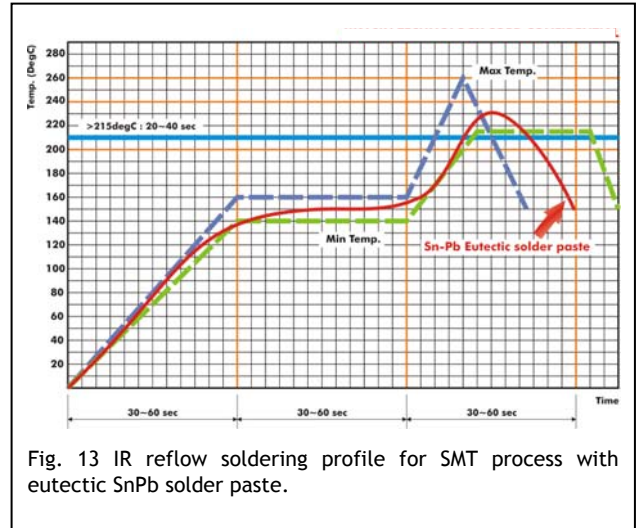

Fig. 13 IR reflow soldering profile for SMT process with eutectic SnPb solder paste.